



VALVES

Series W20 Seal Welded Ball Valves 1/4" - 2" 2000 WOG



FEATURES

- SEAL WELDED CONSTRUCTION
- 2000 WOG Rating on all sizes
- NACE MR-01-75 Compliant
- CF8M Bodies and Tailpieces, 316 Stainless Steel Internals
- Available in Male X Female Construction in 1/4"-1" Sizes
- Standard Actuator Mounting Pads on all sizes
- Standard Locking Stainless Steel Handles
- Locking Stainless Steel Oval Handles Available
- The Ultimate in Safe Design

MOUNTING HOLES
1/4" - 1" 10-24 NC
1" - 1/4"-2" .. 1/4-20 NC

RATINGS
2000 PSIG @ 100F WATER, OIL, GAS
150 PSIG SATURATED STEAM

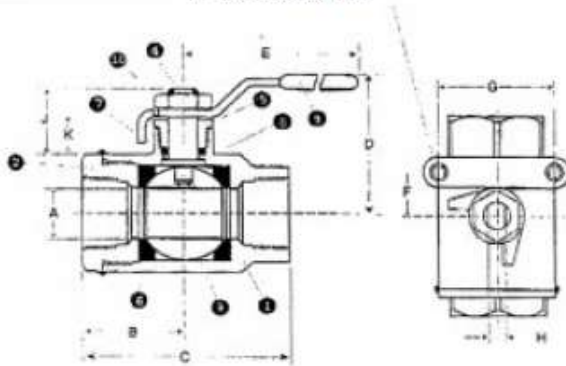

MATERIALS OF CONSTRUCTION

| PART | DESCRIPTION | STANDARD MATERIAL | OPTIONAL MATERIAL |
|------|---------------|-------------------------|------------------------|
| 1 | BODY | ASTM A351 Gr.CF8M | ASTM A351 GR. CF8M |
| 2 | TAILPIECE | ASTM A351 Gr.CF8M | ASTM A351 GR. CF8M |
| 3 | BALL | ASTM A276 Gr.316 | Alloy 20 |
| 4 | STEM | ASTM A276 Gr.316 | Alloy 20 |
| 5 | PACKING NUT | ASTM A276 Gr.316 | Alloy 20 |
| 6 | SEATS (2) | R-PTFE | Steam Seats, PEEK |
| 7 | PACKING | R-PTFE | Graphite, PEEK |
| 8 | THRUST WASHER | R-PTFE | PEEK |
| 9 | HANDLE ASSY | Stainless Steel w/Vinyl | Stainless Locking Oval |
| 10 | HANDLE NUT | Stainless Steel | |

R-PTFE SEATS

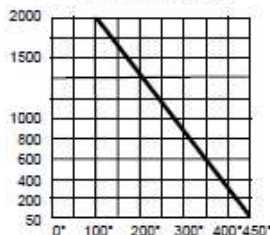

DIMENSIONS, WEIGHTS, CV FACTORS & MAXIMUM OPERATING TORQUE

| SIZE | A | B | C | D | E | F | G | H | J | K | WEIGHT LBS. | Cv Value | MAX TORQUE |
|----------|------|------|------|------|------|------|------|------|------|------|----------------|-------------|---------------|
| 1/4-3/8" | 0.38 | 1.10 | 2.20 | 1.80 | 4.40 | 0.50 | 1.12 | 0.20 | 0.86 | 0.50 | 0.50 | 9 | 40 IN-LB |
| 1/2" | 0.50 | 1.20 | 2.40 | 2.00 | 4.40 | 0.50 | 1.12 | 0.20 | 0.96 | 0.55 | 0.66 | 16 | 75 IN-LB |
| 3/4" | 0.69 | 1.40 | 2.80 | 2.40 | 5.90 | 0.87 | 1.38 | 0.28 | 1.32 | 0.71 | 1.32 | 27 | 120 IN-LB |
| 1" | 0.87 | 1.60 | 3.20 | 2.60 | 5.90 | 0.87 | 1.38 | 0.28 | 1.31 | 0.70 | 1.81 | 42 | 140 IN-LB |
| 1-1/4" | 1.00 | 1.80 | 3.60 | 2.80 | 7.80 | 0.93 | 1.50 | 0.35 | 1.42 | 0.76 | 2.51 | 52 | 250 IN-LB |
| 1-1/2" | 1.30 | 2.10 | 4.10 | 3.00 | 7.80 | 0.93 | 1.50 | 0.35 | 1.42 | 0.76 | 3.74 | 80 | 300 IN-LB |
| 2" | 1.50 | 2.30 | 4.60 | 3.20 | 7.80 | 0.93 | 1.50 | 0.35 | 1.42 | 0.77 | 5.53 | 115 | 320 IN-LB |



VALVES

Series W20 Seal Welded Ball Valves 1/4" - 2" 2000 WOG



FEATURES

- SEAL WELDED CONSTRUCTION
- 2000 WOG Rating on all sizes
- NACE MR-01-75 Compliant
- CF8M Bodies and Tailpieces, 316 Stainless Steel Internals
- Available in Male X Female Construction in 1/4"-1" Sizes
- Standard Actuator Mounting Pads on all sizes
- Standard Locking Stainless Steel Handles
- Locking Stainless Steel Oval Handles Available
- The Ultimate in Safe Design

MOUNTING HOLES
1/4" - 1".....10-24 NC
1" - 1/4"-2".....1/4-20 NC

RATINGS
2000 PSIG @ 100F WATER, OIL, GAS
150 PSIG SATURATED STEAM

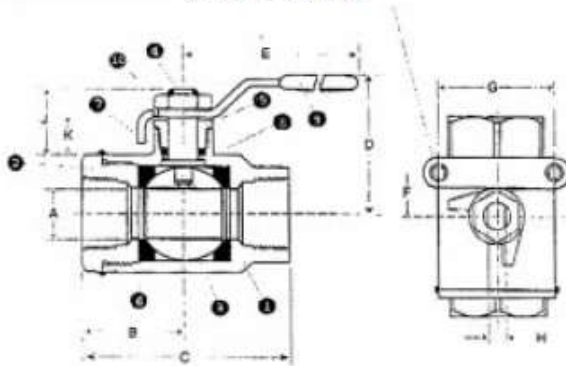

MATERIALS OF CONSTRUCTION

| PART | DESCRIPTION | STANDARD MATERIAL | OPTIONAL MATERIAL |
|------|---------------|-------------------------|------------------------|
| 1 | BODY | ASTM A351 Gr.CF8M | ASTM A351 GR. CF8M |
| 2 | TAILPIECE | ASTM A351 Gr.CF8M | ASTM A351 GR. CF8M |
| 3 | BALL | ASTM A276 Gr.316 | Alloy 20 |
| 4 | STEM | ASTM A276 Gr.316 | Alloy 20 |
| 5 | PACKING NUT | ASTM A276 Gr.316 | Alloy 20 |
| 6 | SEATS (2) | R-PTFE | Steam Seats, PEEK |
| 7 | PACKING | R-PTFE | Graphite, PEEK |
| 8 | THRUST WASHER | R-PTFE | PEEK |
| 9 | HANDLE ASSY | Stainless Steel w/Vinyl | Stainless Locking Oval |
| 10 | HANDLE NUT | Stainless Steel | |

R-PTFE SEATS

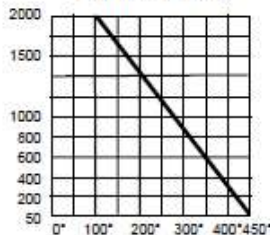

DIMENSIONS, WEIGHTS, CV FACTORS & MAXIMUM OPERATING TORQUE

| SIZE | A | B | C | D | E | F | G | H | J | K | WEIGHT LBS. | Cv Value | MAX TORQUE |
|----------|------|------|------|------|------|------|------|------|------|------|----------------|-------------|---------------|
| 1/4-3/8" | 0.38 | 1.10 | 2.20 | 1.80 | 4.40 | 0.50 | 1.12 | 0.20 | 0.66 | 0.50 | 0.50 | 9 | 40 IN-LB |
| 1/2" | 0.50 | 1.20 | 2.40 | 2.00 | 4.40 | 0.50 | 1.12 | 0.20 | 0.96 | 0.55 | 0.66 | 16 | 75 IN-LB |
| 3/4" | 0.69 | 1.40 | 2.80 | 2.40 | 5.90 | 0.87 | 1.38 | 0.28 | 1.32 | 0.71 | 1.32 | 27 | 120 IN-LB |
| 1" | 0.87 | 1.60 | 3.20 | 2.60 | 6.90 | 0.87 | 1.38 | 0.28 | 1.31 | 0.70 | 1.81 | 42 | 140 IN-LB |
| 1-1/4" | 1.00 | 1.80 | 3.60 | 2.80 | 7.80 | 0.93 | 1.50 | 0.35 | 1.42 | 0.76 | 2.51 | 52 | 250 IN-LB |
| 1-1/2" | 1.30 | 2.10 | 4.10 | 3.00 | 7.80 | 0.93 | 1.50 | 0.35 | 1.42 | 0.76 | 3.74 | 80 | 300 IN-LB |
| 2" | 1.50 | 2.30 | 4.60 | 3.20 | 7.80 | 0.93 | 1.50 | 0.35 | 1.42 | 0.77 | 5.53 | 115 | 320 IN-LB |