



VALVES

STAINLESS STEEL THREE PIECE BALL VALVE

1/4" - 2" 1500 PSI W.O.G.
 2-1/2" - 4" 1000 PSI W.O.G.
 THREADED & SOCKETWELD
 ACTUATOR MOUNTING PAD (3/4"-4" SIZES)

FULL PORT
 BLOW-OUT PROOF STEM
 LOCKING DEVICE

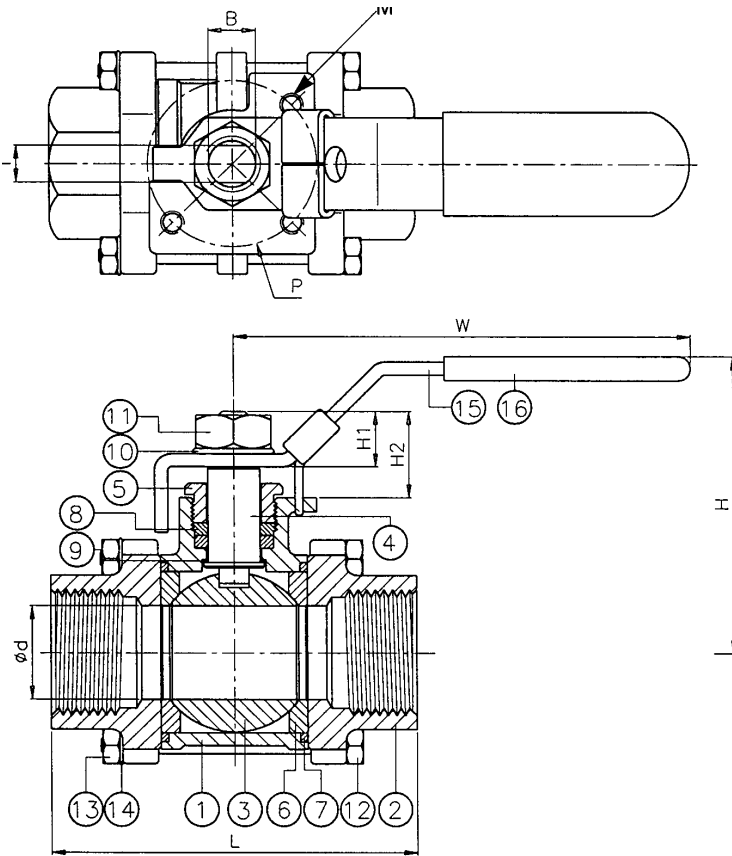
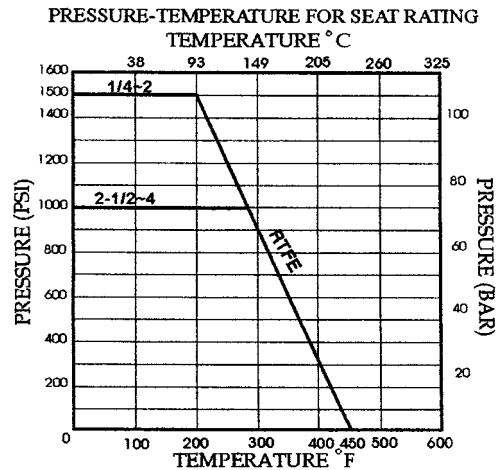

FIGURE NUMBER 1030

ITEM	PART NAME	MATERIAL
1	Body	ASTM A351 CF8M
2	Cap	ASTM A351 CF8M
3	Ball	ASTM A351 CF8M
4	Stem	ASTM A276 316
5	Gland Nut	AISI 304
6	Ball Seat	RTFE
7	Body Seal	PTFE
8	Packing	PTFE
9	Thrust Washer	PTFE
10	Stem Washer	AISI 304
11	Stem Nut	AISI 304
12	Bolt	AISI 304
13	Bolt Nut	AISI 304
14	Spring Washer	AISI 304
15	Handle	AISI 304
16	Handle Sleeve	PVC



Size	d	L	W	H	H1	H2	B	T	P	M	Torque * Inch / lb.	CV Factor Approx.	Wt. (Lbs.) Approx.
1/4"	0.46	2.56	4.13	2.01	0.40	0.55	5/16"	0.20	1.4	3/16" - 24 UNC	35	8.1	0.90
3/8"	0.50	2.56	4.13	2.01	0.40	0.55	5/16"	0.20	1.4	3/16" - 24 UNC	37	14	0.88
1/2"	0.59	2.60	4.92	2.17	0.50	0.73	3/8"	0.26	1.4	3/16" - 24 UNC	50	26	1.43
3/4"	0.79	3.19	4.92	2.36	0.53	0.79	3/8"	0.28	1.4	3/16" - 24 UNC	115	51	1.76
1"	0.98	3.74	6.30	2.91	0.63	0.94	7/16"	0.31	1.7	3/16" - 24 UNC	150	68	2.64
1-1/4"	1.26	4.29	6.30	3.15	0.63	0.94	7/16"	0.31	2	1/4" - 20 UNC	195	120	4.51
1-1/2"	1.50	5.12	7.48	3.62	0.67	1.02	1/2"	0.35	2	1/4" - 20 UNC	240	170	6.16
2"	2.00	5.84	7.48	3.98	0.67	1.02	1/2"	0.35	2.8	5/16" - 18 UNC	390	376	9.57
2-1/2"	2.56	7.09	9.65	5.12	1.16	1.61	3/4"	0.47	2.8	5/16" - 18 UNC	495	510	18.48
3"	3.15	8.11	9.65	5.59	1.16	1.61	3/4"	0.47	4	3/8" - 16 UNC	840	996	31.9
4"	3.94	10.37	12.80	6.85	1.47	1.89	1"	0.63	4	3/8" - 16 UNC	960	1893	58.3

*Estimated torque factors are at full differential pressure and clean service. Certain applications can alter the valve torque significantly. Please take into consideration your service conditions, differential pressure, frequency of operation, temperature, etc. when sizing actuators for our valves.