



VALVES

STAINLESS STEEL ONE PIECE BALL VALVE

**800 PSI W.O.G.
THREADED ENDS**

**BLOW - OUT PROOF STEM
LOCKING DEVICE**

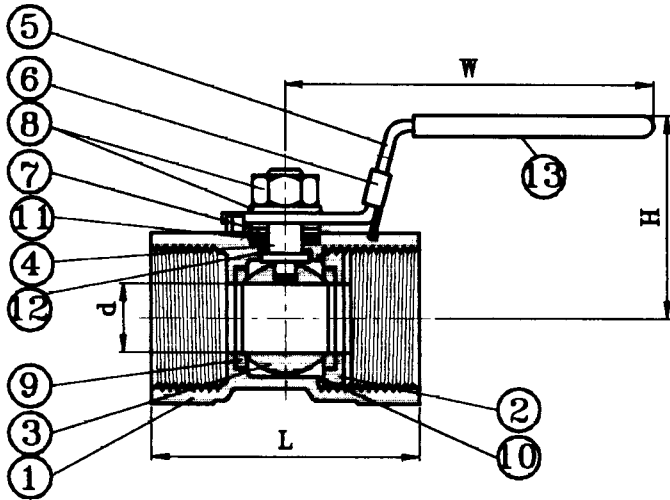

ITEM	PART NAME	MATERIAL
1	Body	ASTM A351-CF8M
2	Retainer	ASTM A351-CF8M
3	Ball	ASTM A351-CF8M
4	Stem	AISI 316
5	Handle	AISI 304
6	Locking Device	AISI 304
7	Disc	AISI 304
8	Nut & Washer	AISI 304
9	Ball Seat	RTFE
10	Body Seal	PTFE
11	Stem Packing	PTFE
12	Thrust Washer	PTFE
13	Handle Sleeve	VINYL

FIGURE NUMBER 1010

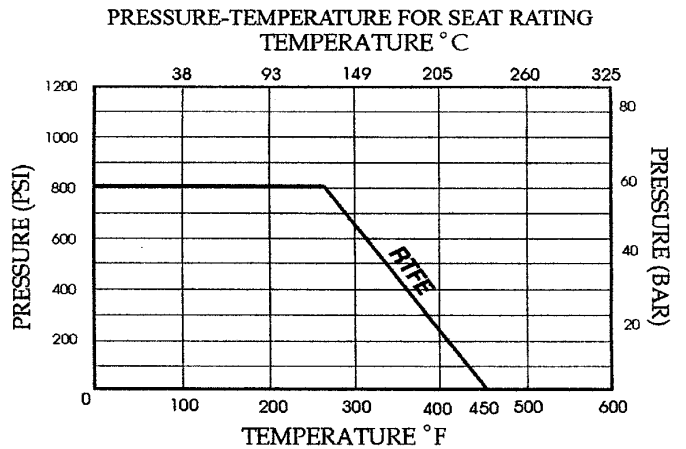

Size	L	W	H	d	CV Factor Approx.	Wt. (Lbs.) Approx.
1/4"	1.535	2.362	1.299	0.197	2.5	0.163
3/8"	1.732	2.952	1.377	0.276	4.5	0.251
1/2"	2.204	3.503	1.653	0.354	7	0.427
3/4"	2.283	3.503	1.811	0.492	9	0.599
1"	2.755	4.173	1.968	0.629	16	0.992
1-1/4"	3.031	4.173	2.204	0.787	24	1.433
1-1/2"	3.228	5.039	2.598	0.964	37	1.895
2"	3.897	5.039	2.834	1.269	68	3.174